

The Use of Polymer Based Gas Sensor for Detecting Formalin in Food Using Artificial Neural Network

by Budi Gunawan

Submission date: 16-Jan-2023 02:26PM (UTC+0700)

Submission ID: 1993470404

File name: r_Detecting_Formalin_in_Food_Using_Artificial_Neural_Network.pdf (493.26K)

Word count: 3944

Character count: 20605

The Use of Polymer Based Gas Sensor for Detecting Formalin in Food Using Artificial Neural Network

Budi Gunawan^{*1}, Arief Sudarmaji²

¹Electrical Engineering, Engineering Faculty, Universitas Muria Kudus
Gondangmanis PO.BOX 53 Bae 59324 Kudus, Central Java - Indonesia

²Agricultural Engineering, Agriculture Faculty, Universitas Jenderal Soedirman
Grendeng, Purwokerto, Banyumas, 53123, Central Java - Indonesia

*Corresponding author; e-mail: budi.gunawan@umk.ac.id

Abstract

The usage of formalin as preservative substance in food is dangerous and make much threat to public society. Yet, it is difficult to identify the presence of formalin in food sensory. It commonly requires laboratory-based testing to detect the formalin. This work describes a detector system of formalin presence in food which employs a series of polymer-based gas sensor and uses a neural network detection method. The sensors are the polymer-carbon composite which made of the polymer mixed with active carbon. There are four types of polymer used, i.e. Polyethylene Glycol (PEG) 6000, PEG200, PEG20M, and PEG1450. The polymer-carbon composite provided a unique characteristic when it is exposed to vapor of food with or without formalin. The resistance of each polymer is different for each detected vapor. The combination of those sensors gives a pattern of voltage output on the sensors when they are exposed certain gas so that every gas has its unique output pattern. The method of detection uses an algorithm of back-propagation of the neural network. That voltage pattern of sensors serves as input to an artificial intelligence program. The result shows that the system has the accuracy of 75% in detecting formalin in food.

Keywords: polymer sensor, formalin detection, artificial neural network

Copyright © 2017 Universitas Ahmad Dahlan. All rights reserved.

1. Introduction

In Indonesian traditional markets, the government control of utilization of prohibited and dangerous substance in food, especially formalin, is still weak. It emerges a fret as well as a worry to the customer, which may cause harm to human health [1,2]. Although adding formalin to foods is forbidden as stated in The Regulation of Indonesian Minister of Health No. 1168/Menkes/PER/X/1999, some industries, especially small/home scale industries still add it in foods and sell them to traditional markets. The Indonesian Agency for Drug and Food Control found that many testing samples of food products of UKM (Small-Medium Industries) are proven to be positive containing formalin [3,4]. These findings show that formalin has become a threat to society. Unfortunately, the presence of formalin in food is difficult to detect sensory by common people. This situation urges not only the role of the Indonesian government to make regulations but also all members of society to actively control the abuse of formalin in food. Availability of quick, simple, accurate, portable device the tool which can detect formalin that can be used by the officers of the Health Agency and the National Agency of Drug and Food Control (BPOM) to monitor regularly and also by related parties on site in order to ensure safety to consumers.

Typically the test of the formalin presence in food is conducted in a laboratory by analysis, expert which needs special reagents, required preliminary treatment and certain procedures. The use of the chemical substance, like Formalin Main Reagen, is also not widely available, expensive, and single-use for on-site application [5,6]. Since the characteristic of formalin is colorless yet it may evaporate into the colorless gas and smells the pungent odor, hence technologically the use of the gas sensor to indicate formalin is potential to be applied. Characteristically, formaldehyde is a colorless, strong-smelling, irritating, poisonous, and flammable gas and its chemical formula are CH_2O which is also known as methanol, commonly produced by the oxidation of methanol [7].

One promising material and technology in the gas sensor is the polymer-based sensor, i.e. Polymer-carbon composite. Such as polymer-carbon composites may provide unique responses (resistance) to certain gas. This resistance varies for each type of polymers as well as the detected gasses. The resistance of polymer-carbon composite may change when it is exposed to the gas. By having the following characteristic polymer-carbon composite can be used as the chemiresistor sensors [8].

Naturally, the polymer is nonconductive. Some types of Polymer can be changed into conductive by adding active carbon. The mixtures of polymer and active carbon are called polymer-carbon composite. The combination of those sensors is aimed at getting the outcome voltage pattern from the sensors when they are exposed to the curtain gas. Thus, every gas will have a unique voltage pattern [9].

The polymer-carbon composite sensor is able to response, stimulus from chemical compound when it is exposed to steam of the chemical substance because when the steam touches the surface of the polymer it diffuses with the mixture of polymer-carbon and causes the size of the polymer is widening because of swelling effect (Figure 1). By this swelling effect, it allows the surface to expand if it is exposed to the gas. This broadens surface affects the resistance of the sensor so that the change of the resistance also influences conductivity of the sensor [10, 11].

The role of the atoms or doping molecules is to cause the flaw in the polymer chain. This flaw serves on the electric conductor. The flaw can be a positive charge, negative or neutral. Physically, the flaw acts as if it is a participle. The flaw can shift along the chain so that it can cause the electric current. An electron or hole can also jump from one flaw to another to produce electric current. The number of flaws rises along with the addition of too many dopant atoms which can lower the mechanical nature of the polymer [12].

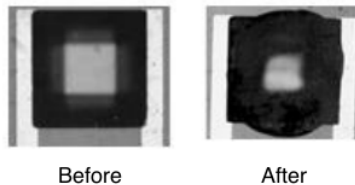

Figure 1. Polymer Swelling Effect

Since there is no certain gas sensor and material of polymer that specifically sensitive to detect formalin only, the use of the series (array) of combination composites of polymer-carbon, which called for the term of electronic-nose, is promising. The early utilization of gas sensor was for detecting the existence of dangerous gasses for human health such as ammonia, sulfide acid, carbon monoxide, or any leak of LPG. Along with the invention of various gas sensors for other chemical substances, the utilization of gas sensors for detecting substances in foods is carried out by making e-nose system. The function of each component of the human's smell organ is adopted using electronic, hard-wear such as the part called receptor uses various sensors which are formed into the array in order to develop artificial organ of smell.

This work presents a use of the array of composites of polymer-carbon (such as Polyethylene Glycol (PEG) 6000, PEG 1540, PEG 20M, and PEG 200) to distinguish (detect) the presence of formalin in food which applied using the principle of electronic nose technology. A microcontroller-based interface is used to acquire the output of composite of polymer-carbon and detection method using the algorithm of the artificial neural network backpropagation. In Indonesian traditional markets, the government control of utilization of prohibited and dangerous substance in food, especially formalin, is still weak. It emerges a fret as well as a worry to the customer, which may cause harm to human health [1,2]. Although adding formalin to foods is forbidden as stated in The Regulation of Indonesian Minister of Health No. 1168/Menkes/PER/X/1999, some industries, especially small/home scale industries still add it in foods and sell them to traditional markets. The Indonesian Agency for Drug and Food Control

found that many testing samples of food products of UKM (Small-Medium Industries) are proven to be positive containing formalin [3, 4]. These findings show that formalin has become a threat to society. Unfortunately, the presence of formalin in food is difficult to detect sensory by common people. This situation urges not only the role of the Indonesian government to make regulations but also all members of society to actively control the abuse of formalin in food. Availability of quick, simple, accurate, portable device the tool which can detect formalin that can be used by the officers of the Health Agency and the National Agency of Drug and Food Control (BPOM) to monitor regularly and also by related parties on site in order to ensure safety to consumers.

Typically the test of the formalin presence in food is conducted in a laboratory by analysis, expert which needs special reagents, required preliminary treatment and certain procedures. The use of the chemical substance, like Formalin Main Reagen, is also not widely available, expensive, and single-use for on-site application [5,6]. Since the characteristic of formalin is colorless yet it may evaporate into the colorless gas and smells the pungent odor, hence technologically the use of the gas sensor to indicate formalin is potential to be applied. Characteristically, formaldehyde is a colorless, strong-smelling, irritating, poisonous, and flammable gas and its chemical formula are CH_2O which is also known as methanol, commonly produced by the oxidation of methanol [7].

One promising material and technology in the gas sensor is the polymer-based sensor, i.e. Polymer-carbon composite. Such as polymer-carbon composites may provide unique responses (resistance) to certain gas. This resistance varies for each type of polymers as well as the detected gasses. The resistance of polymer-carbon composite may change when it is exposed to the gas. By having the following characteristic polymer-carbon composite can be used as the chemiresistor sensors [8].

Naturally, the polymer is nonconductive. Some types of Polymer can be changed into conductive by adding active carbon. The mixtures of polymer and active carbon are called polymer-carbon composite. The combination of those sensors is aimed at getting the outcome voltage pattern from the sensors when they are exposed to the curtain gas. Thus, every gas will have a unique voltage pattern [9].

The polymer-carbon composite sensor is able to response, stimulus from chemical compound when it is exposed to steam of the chemical substance because when the steam touches the surface of the polymer it diffuses with the mixture of polymer-carbon and causes the size of the polymer is widening because of swelling effect (Figure 1). By this swelling effect, it allows the surface to expand if it is exposed to the gas. This broadens surface affects the resistance of the sensor so that the change of the resistance also influences conductivity of the sensor [10,11].

The role of the atoms or doping molecules is to cause the flaw in the polymer chain. This flaw serves on the electric conductor. The flaw can be a positive charge, negative or neutral. Physically, the flaw acts as if it is a participle. The flaw can shift along the chain so that it can cause the electric current. An electron or hole can also jump from one flaw to another to produce electric current. The number of flaws rises along with the addition of too many dopant atoms which can lower the mechanical nature of the polymer [12].

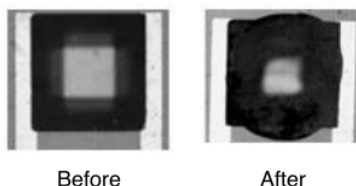

Figure 1. Polymer Swelling Effect

Since there is no certain gas sensor and material of polymer that specifically sensitive to detect formalin only, the use of the series (array) of combination composites of polymer-carbon,

which called for the term of electronic-nose, is promising. The early utilization of gas sensor was for detecting the existence of dangerous gasses for human health such as ammonia, sulfide acid, carbon monoxide, or any leak of LPG. Along with the invention of various gas sensors for other chemical substances, the utilization of gas sensors for detecting substances in foods is carried out by making e-nose system. The function of each component of the human's smell organ is adopted using electronic, hard-wear such as the part called receptor uses various sensors which are formed into the array in order to develop artificial organ of smell.

This work presents a use of the array of composites of polymer-carbon (such as Polyethylene Glycol (PEG) 6000, PEG 1540, PEG 20M, and PEG 200) to distinguish (detect) the presence of formalin in food which applied using the principle of electronic nose technology. A microcontroller-based interface is used to acquire the output of composite of polymer-carbon and detection method using the algorithm of the artificial neural network backpropagation.

2. Experimental

2.1. Polymer Types

There are four types of polymer that were used in this research, namely Polyethylene Glycol (PEG) 6000, PEG 1540, PEG 20M, and PEG 200.

2.2. The Making Process of PEG Based Sensor

The sensor used in this research is made of polymers which are combined with carbon active to form polymer-carbon composite. After that, the material is coated on a board. The dimension of every sensor board is (1.5x2.5) cm and the PCB of the sensor uses interconnection line. The sensor boards are covered with the mixture of polymer and active carbon with composition ratio 1:1 with a coupling agent of Sodium Lauryl Sulfate (SLS) 0.001 g. The process of mixing is that PEG, active carbon and SLS are measured with the mentioned composition, later they are mixed in a beaker glass, added with aqua drop by drop until gel is formed, then the gel is spread onto the boards that are to be the gas sensor, after that the boards are put in the oven for 2 hours in 40 °C, after the heating process in the oven, then they are put inside the dedicator for 1x24 hours to neutralize the oxygen and the other gasses and finally the boards are ready to be the polymer-carbon sensor. The layout of the sensor is presented in Figure 2.



Board sensor

Polymer Sensor

Sensor array

Figure 2. Polymer sensors and sensor array

2.3. The Measured Variables

The testing variables are (1) resistance and output voltage of every sensor, (2) temperature of testing inside the chamber and, (3) the amount of formalin in the tested samples.

2.4. Diagram of Block System

The block system diagram consists of some parts; they are (1) measurement chamber, in which there are heater, temperature sensor, and polymer sensor in the array (2) data acquisition that consists of signal conditioning, ADC and microcontroller (3) battery as the power supply and (4) LCD to display the identification results.

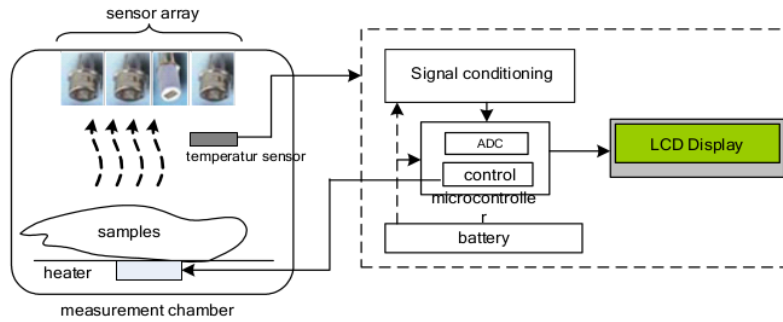

Figure 3. Diagram block system

2.5. Foods Samples

Foods commonly available in traditional markets were used as the research samples; they are (1) tofu, (2) meatball and (3) noodle. The testing was carried out with some temperature variations inside the testing chambers (1) without heating, (2) 40 °C heating, (3) 50 °C heating and (4) 60 °C heating.

2.6. Software Identification

The identification program utilized the neural network. The artificial neural network used is the multi-layer perceptron with backpropagation learning. The data acquisition from the sensors would be used as the input for the artificial neural network and 2 condition criteria of the food samples as the output. The design for multi-layer perceptron (MLP) used 3 layers as shown in Figure 4.

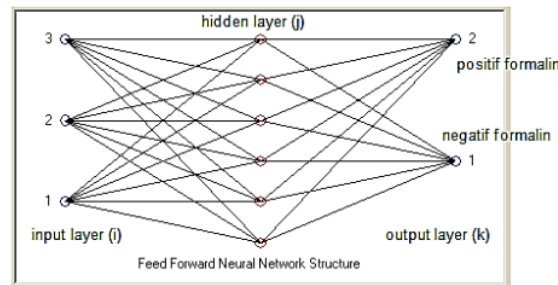

Figure 4. Three-Layer Multi-Layer Perceptron Scheme

The process of learning with backpropagation algorithm in the artificial neural network used equation 1 until 11. The steps of the backpropagation algorithm for learning process in JST 3-layer basically consists of two ways, Forward and Backward steps.

1. Forward steps

Steps in forwarding steps are:

- Normalize the input and desired output (within the range 0-1).
- Give weigh value randomly to (-1) until (+1)
- Give initialization of bias value (1)
- Find the sum and sigmoid for *the Hidden layer* and *Output layer*

a) Hidden Layer

Sum value:

$$Z_j = \sum_{i=0}^N X_i \cdot V_{ij} \quad (1)$$

with N = total synapse layer 2 (hidden layer). Sigmoid value:

$$Z_j' = \frac{1}{1 + e^{-Z_j + bias}} \quad (2)$$

b) Output Layer. Sum value:

$$Y_k = \sum_{j=0}^M Z_j' \cdot W_{jk} \quad (3)$$

with M = total synapse layer 3. Sigmoid value:

$$Y_k' = \frac{1}{1 + e^{-Y_k + bias}} \quad (4)$$

2. Backward Steps

Steps in backward steps are:

a. Calculate the output error (∂_k)

Output error = Output layer 3-desired output

$$Err_k (MSE) = \frac{1}{2} (d_k - Y_k')^2 \quad (5)$$

$$\partial_k = \frac{dErr_k}{dY_k'} = d_k - Y_k' \quad (6)$$

b. Calculate the hidden error (∂_o)

$$\begin{aligned} \partial_o &= \frac{dErr_k}{dZ_j} = \frac{dErr_k}{dY_k} \cdot \frac{dY_k}{dZ_j} \cdot \frac{dZ_j}{dZ_j} \\ Err_j &= \frac{dErr_k}{dY_k} \cdot \frac{dY_k}{dZ_j} = \sum_{k=1}^L \partial_k \cdot W_{jk} \\ \partial_o &= Err_j \cdot Z_j' \cdot (1 - Z_j') \end{aligned} \quad (7)$$

c. Updating weight for weight on Hidden-Output layer

$$\begin{aligned} \Delta W_{jk} &= \eta \cdot \frac{dErr_k}{dW_{jk}} = \eta \cdot \frac{dErr_k}{dY_k} \cdot \frac{dY_k}{dW_{jk}} = \eta \cdot \partial_k \cdot Z_j' \\ W_{jk} &= W_{jk} + \Delta W_{jk} \end{aligned} \quad (8)$$

d. Updating bias value on output layer

$$\Delta bias_k = \eta \cdot \frac{dErr_k}{dbias_k} = \eta \cdot \frac{dErr_k}{dY_k'} \cdot \frac{dY_k'}{dbias_k} = \eta \cdot \partial_k \cdot 1$$

$$bias_k = bias_k + \Delta bias_k \quad (9)$$

e. Updating weight for weight on Input – Hidden layer

$$\Delta V_{ij} = \eta \cdot \frac{dErr_j}{dV_{ij}} = \eta \cdot \frac{dErr_j}{dZ_j'} \cdot \frac{dZ_j'}{dV_{ij}} = \eta \cdot \partial_o \cdot X_i$$

$$V_{ij} = V_{ij} + \Delta V_{ij} \quad (10)$$

f. Updating bias on hidden layer

$$\Delta bias_j = \eta \cdot \frac{dErr_j}{dbias_j} = \eta \cdot \frac{dErr_j}{dZ_j'} \cdot \frac{dZ_j'}{dbias_j} = \eta \cdot \partial_o \cdot 1$$

$$bias_j = bias_j + \Delta bias_j \quad (11)$$

The artificial neural network program was made with *backpropagation* algorithm using Visual basic 6.0 program.

2.7. Program Flowchart

The flowchart of the learning process and identification process are shown in Figure 5.

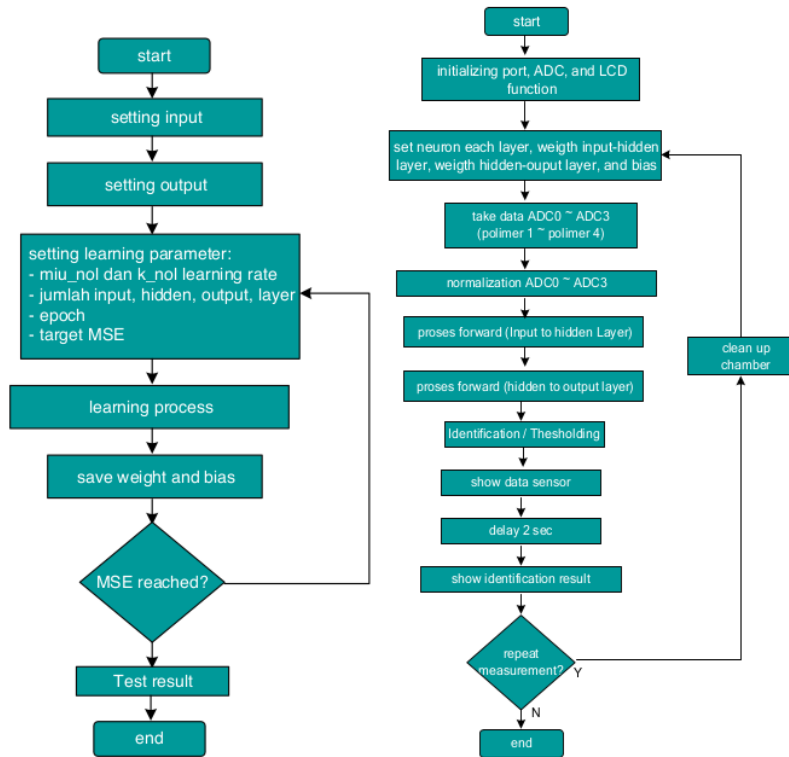

Figure 5. Flowchart of (a) learning process and (b) identification process

3. Results and Analysis

3.1. Data Acquisitions

The data acquisition circuit (Figure 6) is integrated into one board with the heating circuit and its control as the heater in the chamber, put the samples and LCD circuit to display the results of sensor detection which had been processed by the artificial neural network inside the microcontroller.

3.2. Heater and Temperature Control Series

The heater and temperature control (Figure 7) are used to give various temperature conditions in accordance with the test set that is controlled by a microcontroller with some relays. To set the desired temperature, the LCD is used to display the set point and to measure the temperature inside the test chamber.



Figure 6. Data Acquisition Board

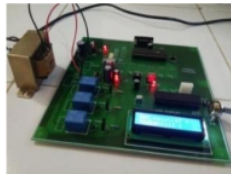

Heater and temperature control



LCD for setting point

Figure 7. Heater and Temperature Control Series

3.3. LCD for Displaying the Results of Identification

The LCD is utilized to display the results from this portable detector which shows three detection states, they are 1) "Containing formalin" if the food sample was detected to contain formalin 2) "Not containing formalin" if the food sample did not contain any formalin, and 3) "Not yet identified" if the sample contained gas but not formalin that had not been learnt in the program of the artificial neural network.

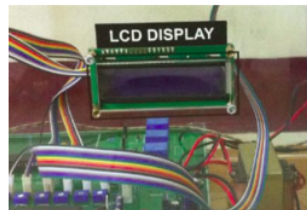

Figure 8. LCD for Displaying Identification Results

3.4. Realization of Whole Hardware

The realization of the system of a portable detector of formalin in foods is shown in Figure 9.



A data acquisition circuit and sensor



A portable system

Figure 9. A portable formalin detector

3.5. The Test Results

On the sample testing (meatball, tofu, and noodle), the sensor's response was tested by exposing it to two conditions with and without formalin. Each condition was tested on four conditions without heating, 400C heating, 500C heating, and 600C. Each test was conducted three times. The results of the tests for each sample later were used as training data for the artificial neural network. This training was for 'teaching' each sensor in identifying the presence of formalin in the detected commodity based on the response showed in the test results. In the training, each sensor would be trained to detect the presence of formalin with the output target 1 if the detected sample contained formalin and 0 if the detected sample did not contain formalin. After the program had been trained and put in the system, the next was that the system used in the real tests to find out how accurate was the system in detecting the samples containing formalin and not containing formalin. The average percentages of test results from three food samples with four testing conditions and three repetitions are (1) without formalin: 91.7%, (2) with formalin: 75%.

4. Conclusion

It has been building a detection system for formalin addition in foods which is portable and using a sensor made of polymer with a detection software on an artificial neural network. This research utilizes four types of polymers, namely polyethylene glycol (PEG) 6000, PEG 1540, PEG 20M, and PEG 200 as the gas sensor. The results show that a polymer which typically is an insulator in nature when it is combined with active carbon will become a conductor which has the unique characteristic having various resistance values to each commodity contaminated or not with formalin. As the detection software, it uses artificial intelligence that is an artificial neural network. The test shows that the performance in detecting formalin in foods reaches 75%. Moreover, for the next studies, this study also suggests that there is a possibility to use a sensor using metal oxide semiconductor (MOS) and compare the result with the sensor used in this research.

References

- [1] N Noordiana, AB Fatimah, YCB Farhana. Formaldehyde content and quality characteristics of selected fish and seafood from wet markets. *Int. Food Res. J.* 2011; 18: 125–136.
- [2] R Uddin, MI Wahid, T Jesmeen, NH Huda, KB Sutradhar. Detection of formalin in fish samples collected from Dhaka city, Bangladesh. *Stamford J. Pharm. Sci.* 2011; 4: 49–52.
- [3] Media Industry. Penyalahgunaan Formalin dan Peran Pemerintah. *Media Ind.* No. 21.III. 2006: 5–9.
- [4] Detik Finance. Industri Besar Jauhi Formalin, Sebagian UKM Masih Pakai. 2007. <https://finance.detik.com/berita-ekonomi-bisnis/d-809653/industri-besar-jauhi-formalin-sebagian-ukm-masih-pakai> (accessed September 28, 2017).

-
- [5] Y Drastini, DA Widiasih. Studi Metode Schiff Untuk Deteksi Kadar Formalin Pada Ikan Bandeng Laut (Chanos-Chanos). *J. Sains Vet.* 2009; 27.
- [6] RG Liteplo, R Beauchamp, ME Meek, R Chénier. *Concise International Chemical Assessment Document 40: Formaldehyde*. IPCS Concise Int. Chem. Assess. Doc. 2002.
- [7] B Gunawan, M Rivai, H Juwono. Characterization of polymeric chemiresistors for gas sensor. *Telkomnika.* 2012; 10.
- [8] PW Atkins. *Physical Chemistry*. New York: WH Freeman. 1990.
- [9] J Janata, M Josowicz. Conducting polymers in electronic chemical sensors. *Nat. Mater.* 2003; 2: 19–24.
- [10] H Bai, G Shi. Gas Sensors Based on Conducting Polymers. *Sensors.* 2007; 7: 267–307.
- [11] F Zee, J Judy. MEMS chemical gas sensor using a polymer-based array. 1999.
- [12] KJ Albert, NS Lewis, CL Schauer, GA Sotzing, SE Stitzel, TP Vaid, et al. Cross Reactive Chemical Sensor Arrays. *Chem. Rev.* 2000; 100: 2595–2626.

The Use of Polymer Based Gas Sensor for Detecting Formalin in Food Using Artificial Neural Network

ORIGINALITY REPORT

15%

SIMILARITY INDEX

14%

INTERNET SOURCES

1%

PUBLICATIONS

12%

STUDENT PAPERS

PRIMARY SOURCES

1	Submitted to Universitas Sumatera Utara Student Paper	6%
2	Submitted to Universitas Muria Kudus Student Paper	4%
3	psasir.upm.edu.my Internet Source	2%
4	id.123dok.com Internet Source	1%
5	adoc.pub Internet Source	1%
6	Submitted to School of Business and Management ITB Student Paper	1%
7	core.ac.uk Internet Source	1%
8	dspace.ewubd.edu Internet Source	<1%

Exclude quotes Off

Exclude matches Off

Exclude bibliography On

The Use of Polymer Based Gas Sensor for Detecting Formalin in Food Using Artificial Neural Network

GRADEMARK REPORT

FINAL GRADE

/0

GENERAL COMMENTS

Instructor

PAGE 1

PAGE 2

PAGE 3

PAGE 4

PAGE 5

PAGE 6

PAGE 7

PAGE 8

PAGE 9

PAGE 10
